

**Patons®**  
*Classic Wool*

**Patons®**  
**DECOR**



## CASUAL CABLES (FOR HIM)

### SIZES

#### Chest measurement

<b>Small</b>	34-36 ins [86-91 cm]
<b>Medium</b>	38-40 ins [97-102 cm]
<b>Large</b>	42-44 ins [107-112cm]

#### Finished chest

<b>Small</b>	44 ins [113 cm]
<b>Medium</b>	48 ins [122 cm]
<b>Large</b>	53 ins [134.5 cm]

## MATERIALS

**Patons Classic Wool** (100 g/3.5 oz)  
 or **Patons Décor** (100 g/3.5 oz)  
**Size**    **S**    **M**    **L**

9    10    11 balls

Sizes 4 mm (U.S. 6) and 4.5 mm (U.S. 7) knitting needles **or sizes needed to obtain tension.** Cable needle. 2 st holders.

## TENSION

20 sts and 26 rows = 4 ins [10 cm] with larger needles in stocking st.

## ABBREVIATIONS

**M1** = Make 1 st by picking up horizontal loop lying before next st and knitting into back of loop.

**K1B** = knit into back loop of next stitch.

**P1B** = purl into back loop of next stitch.

**C3Ftbl** = slip next 2 sts onto a cable needle and hold at front of work. K1B, then K2 from cable needle.

**C3Btbl** = slip next st onto a cable needle and hold at back of work. K2, then K1B from cable needle.

**C3F** = slip next 2 sts onto a cable needle and hold at front of work. P1, then K2 from cable needle.

**C3B** = slip next st onto a cable needle and hold at back of work. K2, then P1 from cable needle.

**C4F** = slip next 2 sts onto a cable needle and hold at front of work. K2, then K2 from cable needle.

**T5R** = slip next 2 sts onto a cable needle and hold at back of work. K1B, then (P1. K1) from cable needle.

**T5L** = slip next stitch to cable needle and hold at front of work. (K1B. P1), then K1 from cable needle.

**T7B** = slip next 4 sts onto a cable needle and leave at back of work. (K1B. P1. K1B), then (P1. K1B) twice from cable needle.

## INSTRUCTIONS

*The instructions are written for smallest size. If changes are necessary for larger sizes the instructions will be written thus ( ).*

### BACK

\*\*With smaller needles, cast on 143 (157-171) sts.

**1st row:** (RS). K1. P1. \*K2. P1. (K1B. P1) 4 times. K2. P1. Rep from \* to last st. K1.

**2nd row:** P1. K1. \*P2. K1. (P1B. K1) 4 times. P2. K1. Rep from \* to last st. P1.

Rep last 2 rows until work from beg measures for 2 ins [5 cm] ending with RS facing for next row.



ABBREVIATIONS: [www.patonsyarns.com/glossary](http://www.patonsyarns.com/glossary)

Change to larger needles and proceed in rib pat as follows:

**1st row:** K1. \*P1. C3Ftbl. (K1B. P1) 3 times. K1B. C3Btbl. Rep from \* to last 2 sts. P1. K1.

**2nd row:** P1. \*K1. P4. (K1. P1B) twice. K1. P4. Rep from \* to last 2 sts. K1. P1.

**3rd row:** K1. P1. K1B. \*C3F. (P1. K1B) twice. P1. C3B. K1B. P1. K1B. Rep from \* ending last rep with P1. K1.

**4th row:** P1. K1. P1B. \*K1. P2. (K1. P1B) twice. Rep from \* ending last rep with K1. P1.

**5th row:** K1. P1. K1B. \*P1. C3Ftbl. K1B. P1. K1B. C3Btbl. (P1. K1B) twice. Rep from \* ending last rep with P1. K1B. P1. K1.

**6th row:** P1. K1. P1B. \*(K1. P4) twice. (K1. P1B) twice. Rep from \* ending last rep with K1. P1.

**7th row:** K1. P1. K1B. P1. \*K1B. C3F. P1. C3B. (K1B. P1) 3 times. Rep from \* ending last rep with (K1B. P1) twice. K1.

**8th row:** P1. K1. (P1B. K1) twice. \*P2. K1. P2. (K1. P1B) 4 times. K1. Rep from \* ending last rep with (K1. P1B) twice K1. P1.

**9th row:** K1. P1. (K1B. P1) twice. \*Slip next 2 sts onto a cable needle and hold at front of work. K2tog. K1. K2 from cable needle. (P1. K1B) 4 times. P1. Rep from \* ending last rep with (P1. K1B) twice. P1. K1. 133 (146-159) sts.

**10th row:** P1. \*K1. (P1B. K1) twice. P4. (K1. P1B) twice. Rep from \* ending last rep with K1. P1.

**11th row:** K1. \*P1. (K1B. P1) twice. K4. (P1. K1B) twice. Rep from \* ending last rep with P1. K1.

**12th row:** As 10th row.

**13th row:** K1. \* P1. (K1B. P1) twice. C4F. (P1. K1B) twice. Rep from \* ending last rep with P1. K1.

**14th to 16th rows:** As 10th to 12th rows once.

**17th row:** K1. P1. (K1B. P1) twice. \*C4F. P1. K1B. P1. T5R. P1. K1B. P1. Rep from \* ending last rep with K1B. P1. K1.

**18th row:** As 10th row.

**19th row:** K1. P1. (K1B. P1) twice. \*K4. P1. T5R. P1. T5L. P1. Rep from \* ending last rep with K4. (P1. K1B) twice. P1. K1.

**20th row:** As 10th row.

These 20 rows form rib pat.

Proceed in cable pat as follows:

**1st row:** (RS). K1. \*P1. (K1B. P1) twice. C4F. (P1. K1B) twice. Rep from \* to last 2 sts. P1. K1.

**2nd and alt rows:** P1. \*K1. (P1. K1) twice. P4. (K1. P1) twice. Rep from \* to last 2 sts. K1. P1.

**3rd row:** K1. \*P1. (K1B. P1) twice. K4. (P1. K1B) twice. Rep from \* to last 2 sts. P1. K1.

**5th row:** As 1st row.

**7th row:** K1. P1. (K1B. P1) twice. \*K4. P1. T7B. P1. Rep from \* to last 10 sts. K4. (P1. K1B) twice. P1. K1.

**8th row:** As 2nd row.

These 1st to 8th rows form cable pat.

Rep last 8 rows until work from beg measures 16 (16½-17½) ins [40.5 (42-44.5) cm] ending with RS facing for next row.

**Armhole shaping:** Keeping cont of cable pat, cast off 9 (9-11) sts beg next 2 rows.\*\*

Cont even in pat until work from beg measures 26 (27-28) ins [66 (68.5-71) cm] ending with RS facing for next row.

**Shoulder shaping:** Keeping cont of pat, cast off 12 (14-15) sts beg next 4 rows, then 12 (13-15) sts beg following 2 rows. Leave rem 43 (46-47) sts on a st holder.

## FRONT

Work from \*\* to \*\* as given for Back.

Cont even in pat until work from beg measures 20 (21-22) ins [51 (53.5-56) cm] ending with RS facing for next row.

**V-neck shaping: Next row:** Pat 56 (64-68) sts across. **Turn.** Leave rem sts on a spare needle.

Dec 1 st at neck edge every row 12 times, then every alt row 10 (11-11) times. 36 (41-45) sts.

Cont even in pat until work from beg measures 26 (27-28) ins [66 (68.5-71) cm] ending with RS facing for next row.

**Shoulder shaping:** Keeping cont of pat, cast off 12 (14-15) sts beg next and following alt row. Work 1 row even. Cast off rem 12 (13-15) sts.

**Sizes S and L only:** With RS of work facing, slip 1 st on a safety pin. Join yarn to rem sts and pat to end of row.

**All sizes:** Keeping cont of pat, dec 1 st at neck edge every row 12 times then every alt row 10 (11-11) times. 36 (41-45) sts.

Cont even in pat until work from beg measures 26 (27-28) ins [66 (68.5-71) cm] ending with **WS** facing for next row.

**Shoulder shaping:** Keeping cont of pat, cast off 12 (14-15) sts beg next and following alt row. Work 1 row even. Cast off rem 12 (13-15) sts.

## SLEEVES

With smaller needles, cast on 73 sts.

**1st row:** (RS). K1. P1. \*K2. P1. (K1B. P1) 4 times. K2. P1. Rep from \* to last st. K1.

**2nd row:** P1. K1. \*P2. K1. (P1B. K1) 4 times. P2. K1. Rep from \* to last st. P1.

Rep last 2 rows until work from beg measures 2 ins [5 cm].

Change to larger needles and proceed in rib pat as given for Back, inc 1 st each end of needle on 9th row, then every alt row 5 (8-8) times, then every 4th row 20 times, taking inc sts into rib pat. 124 (131-131) sts.

Work in cable pat, inc 1 st each end of needle every 4th row from previous inc to 130 (136-136) sts.

Cont even in pat until sleeve from beg measures 19 (19½-19½) ins [48 (49.5-49.5) cm] ending with RS facing for next row. Cast off.

Place markers each side of sleeve 1 (2-2) ins [2.5 (5-5) cm] below cast off edge.

## FINISHING

Pin garment pieces to measurements. Cover with a damp cloth leaving to dry.

**Neckband:** Sew right shoulder seam. With RS of work facing and smaller needles, pick up and knit 36 sts down left front neck edge. K1 from safety pin and mark as center st. Pick up and knit 36 sts up right front neck edge. Knit 43 (46-47) sts from back st holder, dec 0 (1-0) sts at center. 116 (118-120) sts.

**1st row:** \*K1B. P1. Rep from \* to center 5 sts. P2tog. K1B. P2tog. Rib to end of row.

**2nd row:** Rib to center 5 sts. K2tog. K1B. K2tog. Rib to end of row.

**3rd to 6th rows:** As 1st to 2nd rows twice more.

Cast off in rib, dec 3 sts at center as before.

Sew left shoulder and neckband seam. Cont working even in pat until sleeve from beg measures 19 (19½-19½) ins [48 (49.5-49.5) cm] ending with RS facing for next row. Cast off.

Sew in sleeves placing rows above markers along cast off sts at armholes to form square armholes. Sew side and sleeve seams.

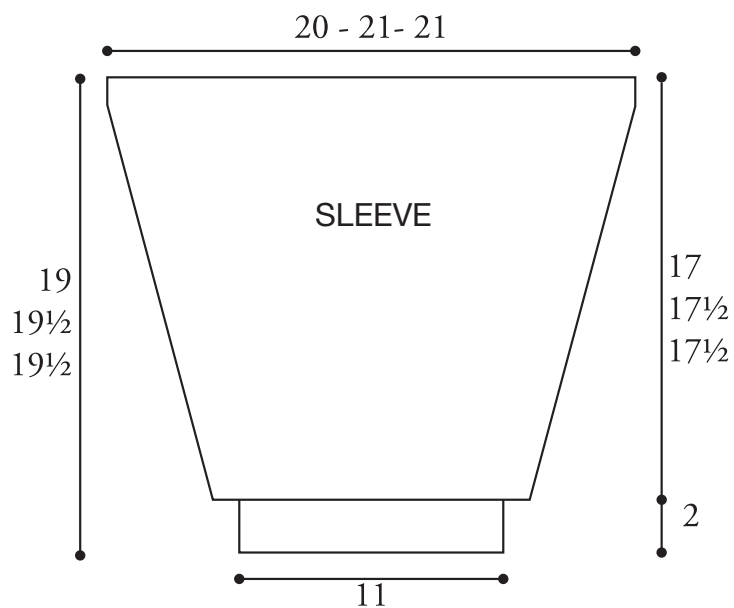
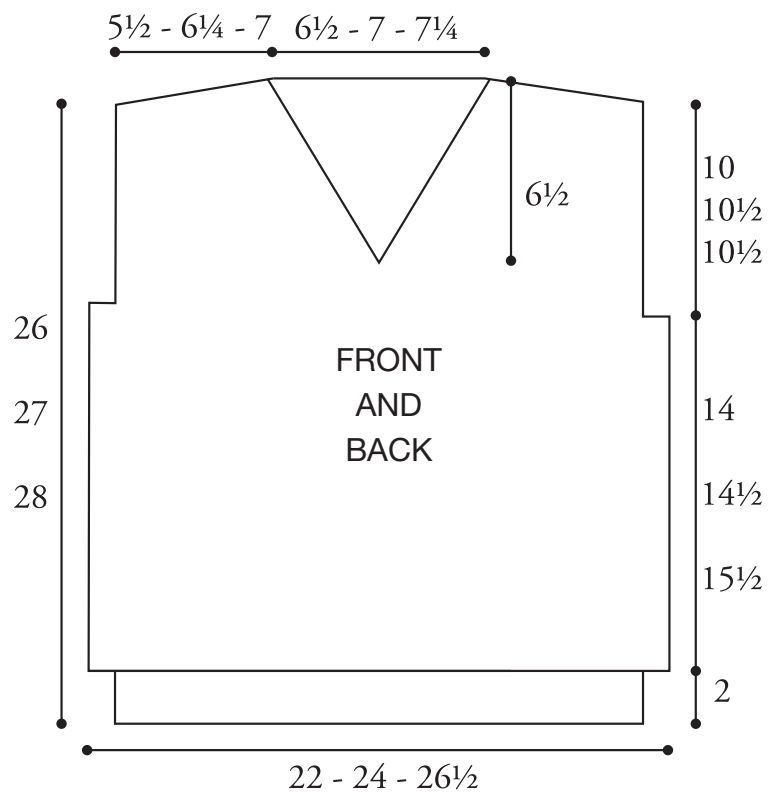

**Patons**

*... a part of your life.*

P.O. Box 40, Listowel ON N4W 3H3