

Patons Grace



PATONS® GRACE PRETTY V NECK (TO CROCHET)

SIZES

Bust measurement

X-Small/Small 32-34 ins [81.5-86.5 cm]

Medium/Large 36-38" [91.5-96.5"]

X-Large 40" [101.5"]

Finished bust

X-Small/Small 36 ins [91.5 cm]

Medium/Large 40" [101.5"]

X-Large 44" [112"]

MATERIALS

Patons® Grace (50 g)

Sizes XS/S (M/L-XL)

(Natural) **9 (10-11) balls**

Sizes 3.25 mm (U.S. D or 3) and 3.5 mm (U.S. E or 4) crochet hooks **or size needed to obtain tension.**

TENSION

4 Shells and 13 rows = 4 ins [10 cm] in pat with smaller hook.

INSTRUCTIONS

The instructions are written for smallest size. If changes are necessary for larger sizes the instructions will be written thus ().

FRONT

** With larger hook, ch 110 (122-134).

Foundation row: (RS). 1 sc in 2nd ch from hook. *Miss next 2 ch. [(1 dc. Ch 2) twice.

1 dc] all in next ch - Shell made. Miss next 2 ch.

1 sc in next ch. Rep from * to end of ch. 18 (20-22) Shells.

1st row: Ch 5 (counts as dc and ch 2). 1 dc in first sc. *Miss next dc and ch 2 sp. 1 sc in next dc (top of Shell). Miss next ch 2 sp and dc. Shell in next sc. Rep from * to last Shell. Miss next dc and ch-2 sp. 1 sc in next dc (top of Shell). (1 dc. Ch 2. 1 dc) all in last sc. Turn.

2nd row: Ch 1. 1 sc in first dc. *Shell in next sc. Miss next dc and ch-2 sp. 1 sc in top of Shell. Miss next dc and ch 2 sp. Rep from * to last sc. Shell in next sc. 1 sc in 3rd ch of turning ch 5. Turn.

Last 2 rows form pat.

Cont in pat until work from beg measures 16 (16½-17) ins [40 (42-43) cm], ending with RS facing for next row.

Armhole shaping: 1st row: Sl st in first dc, ch-2 sp, dc, sc, (dc, ch-2 sp) twice, dc, sc, dc, ch-2 sp and dc. Ch 1. 1 sc in same sp as last sl st. Pat to last 2 shells. Miss next dc, ch-2 sp.

1 sc in next dc. **Turn.** Leave rem sts unworked. 14 (16-18) Shells.

2nd row: Sl st in first sc, dc, ch-2 sp and dc. Ch 1. 1 sc in same sp as last sl st. Pat to last Shell. Miss next dc and ch-2 sp. 1 sc in next dc. **Turn.** Leave rem sts unworked.

Rep last row 1 (1-2) time(s) more. 12 (14-14) Shells.**

Sizes XS/S and M/L only: Work 1 row even in pat.

All Sizes: V-neck shaping: 1st row: (RS). Pat across 6 (7-7) Shells, ending with 1 sc in top of last shell. **Turn.** Leave rem sts unworked.

2nd row: Ch 3 (counts as dc). 1 dc in first sc. 1 sc in top of next Shell. Pat to end of row. Turn.

3rd row: Pat across ending with 1 sc in top of last Shell. (1 dc. Ch 2. 1 dc) in next sc. 1 dc in top of turning ch 3. Turn.

4th row: Ch 3. Miss first 2 dc. 1 dc in next ch-2 sp. Miss next dc. Shell in next sc. Pat to end of row. Turn.

5th row: Pat across ending with 1 sc in top of last Shell. 1 dc in top of turning ch 3. Turn.

6th row: Ch 3. Miss first dc. (1 dc. Ch 2. 1 dc) in next sc. 1 sc in top of next Shell. Pat to end of row. Turn.

7th row: Pat across to last sc. (1 dc. Ch 2. 1 dc) in last sc. 1 dc in top of turning ch 3. Turn. Rep 4th to 7th rows 1 (2-2) time(s) more then 4th and 5th rows once.

Cont even in pat until armhole measures 7 (7½-8) ins [18 (19-20.5) cm], ending with RS facing for next row. Fasten off.



ABBREVIATIONS: www.patonsyarns.com/glossary

With RS of work facing, join yarn with sl st in same dc as last sc. Ch 1. 1 sc in same sp as last sl st. Pat to end of row. Turn.

2nd row: Pat to last sc. 2 dc in last sc. Turn.

3rd row: Ch 3 (counts as dc). Miss first 2 dc. (1 dc. Ch 2. 1 dc) in next sc. 1 sc in top of next Shell. Pat to end of row. Turn.

4th row: Pat to last sc. Shell in last sc. 1 dc in next ch-2 sp. Miss next dc. 1 dc in top of turning ch. Turn.

5th row: Ch 3 (counts as dc). 1 sc in top of next Shell. Pat to end of row. Turn.

6th row: Pat to last Shell. 1 sc in top of last Shell. (1 dc. Ch 2. 1 dc) in next sc. 1 dc in top of turning ch. Turn.

7th row: Ch 3 (counts as dc). (1 dc. Ch 2. 1 dc) in next sc. 1 sc in top of next Shell. Pat to end of row. Turn.

Rep 4th to 7th rows 1 (2-2) time(s) more then 4th and 5th rows once. 3 Shells.

Cont even in pat until armhole measures 7 (7½-8) ins [18 (19-20.5 cm)], ending with RS facing for next row. Fasten off.

BACK

Work from ** to ** as given for Front.

Cont even in pat until armhole measures same length as Front to shoulders, ending with RS facing for next row. Fasten off.

SLEEVES

With smaller hook, ch 74 (80-86).

Foundation row: (RS). 1 sc in 2nd ch from hook. *Miss next 2 ch. Shell in next ch. Miss next 2 ch. 1 sc in next ch. Rep from * to end of row. 12 (13-14) Shells.

Work even in pat as given for Front for 9 more rows.

Shape top: Next row: (RS). Sl st in first dc, ch-2 sp, dc, sc, dc, ch-2 sp and dc. Ch 1. 1 sc in same sp as last sl st. Pat to last Shell. Miss next dc and ch-2 st. 1 sc in next dc. **Turn.** Leave rem sts unworked. 10 (11-12) Shells.

2nd row: Sl st in first sc, dc, ch-2 sp and dc. Ch 1. 1 sc in same sp as last sl st. Pat to last Shell. Miss next dc and ch-2 sp. 1 sc in next dc. **Turn.** Leave rem sts unworked.

Rep last row until there are 2 (3-3) Shells.

Fasten off.

FINISHING

Sew shoulder seams.

With RS of work facing and smaller hook, join yarn with sl st to neck edge at left shoulder seam. Ch 1. Work 1 row of sc evenly around neck edge, working Sc2tog at bottom point of V neck as follows: (*Yoh and draw up a loop twice. Yoh and draw through all loops on hook--* Sc2tog made. Ch 1. **Do not** turn.

Next row: Working from left to right instead of from right to left as usual, work 1 reverse sc in each sc around. Join with sl st to first reverse sc. Fasten off.

Front or Back Bottom Edging: With RS of work facing and larger hook, join yarn with sl st in first rem loop of foundation ch. Ch 1. 1 sc in same sp as last sl st. *Miss next 2 ch. (3 dc. Ch 3. Sl st to top of last dc - Picot made. 2 dc) in next ch. Miss next ch. 1 sc in next ch. Rep from * to end of row. Fasten off.

Sleeve Bottom Edging: With smaller hook, work as given for Front or Back Bottom Edging.

Sew in Sleeves. Sew side and sleeve. seams.

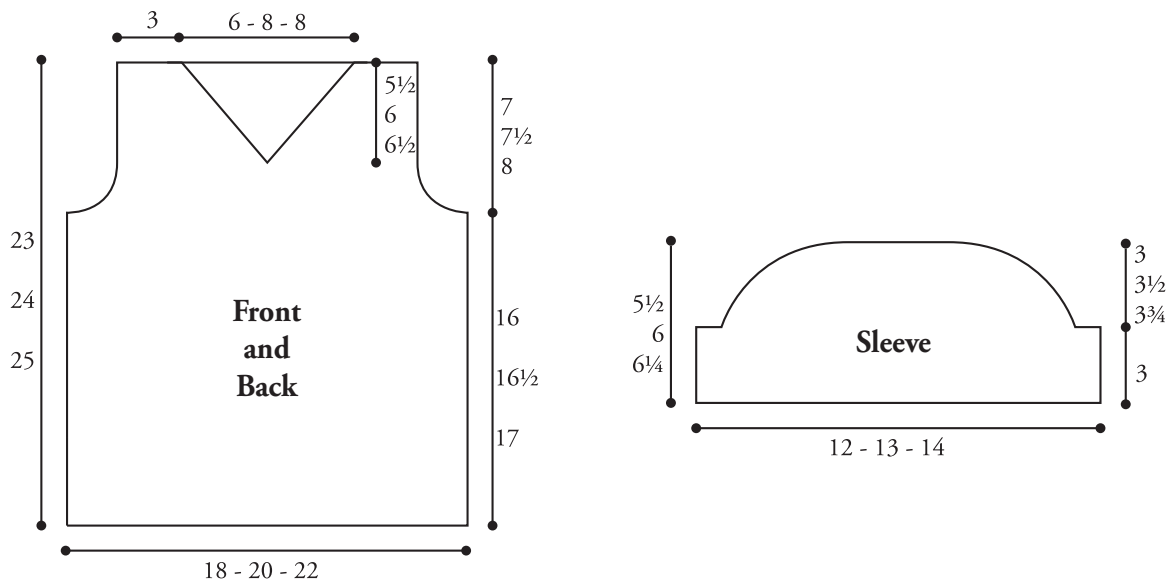

Patons

... a part of your life.

P.O. Box 40, Listowel ON N4W 3H3